

## MaxiFil stationär

EN – Operating Manual

Typenschild einkleben



<b>1</b>	<b>General .....</b>	<b>- 6 -</b>
1.1	Introduction.....	- 6 -
1.2	References to copyright and industrial property rights.....	- 6 -
1.3	Notes for the operating company .....	- 6 -
<b>2</b>	<b>Safety.....</b>	<b>- 8 -</b>
2.1	General information .....	- 8 -
2.2	Information on signs and symbols.....	- 8 -
2.3	Markings/signs to be affixed by the operating company .....	- 9 -
2.4	Safety instructions for operating staff .....	- 9 -
2.5	Safety instructions for maintenance/troubleshooting.....	- 10 -
2.6	Notes regarding special types of hazard .....	- 10 -
<b>3</b>	<b>Product information.....</b>	<b>- 13 -</b>
3.1	Functional description.....	- 13 -
3.2	Distinguishing feature – W3 certified .....	- 14 -
3.3	Intended use.....	- 14 -
3.4	General requirements in accordance with DIN EN ISO 21904 .....	- 16 -
3.5	Reasonably foreseeable misuse .....	- 16 -
3.6	Markings and signs on the product.....	- 17 -
3.7	Residual Risk .....	- 17 -
<b>4</b>	<b>Transport and Storage .....</b>	<b>- 19 -</b>
4.1	Transport .....	- 19 -
4.2	Storage .....	- 19 -
<b>5</b>	<b>Assembly.....</b>	<b>- 20 -</b>
5.1	Unpacking the product .....	- 21 -
5.2	Installation of the product.....	- 23 -
<b>6</b>	<b>Use .....</b>	<b>- 30 -</b>
6.1	Qualification of the operating personnel .....	- 30 -
6.2	Operating elements.....	- 30 -
6.3	Positioning the extraction hood .....	- 31 -
6.4	Commissioning .....	- 32 -
<b>7</b>	<b>Maintenance .....</b>	<b>- 34 -</b>
7.1	Care.....	- 34 -
7.2	Maintenance.....	- 35 -

---

<b>7.3</b>	<b>Maintenance</b> .....	<b>- 35 -</b>
<b>7.3.1</b>	<b>Changing the filter – Safety instructions</b> .....	<b>- 35 -</b>
<b>7.3.2</b>	<b>Changing filters</b> .....	<b>- 37 -</b>
<b>7.4</b>	<b>Troubleshooting</b> .....	<b>- 41 -</b>
<b>7.5</b>	<b>Emergency measures</b> .....	<b>- 42 -</b>
<b>8</b>	<b>Disposal</b> .....	<b>- 43 -</b>
<b>8.1</b>	<b>Plastics</b> .....	<b>- 43 -</b>
<b>8.2</b>	<b>Metals</b> .....	<b>- 43 -</b>
<b>8.3</b>	<b>Filter elements</b> .....	<b>- 43 -</b>
<b>9</b>	<b>Annex</b> .....	<b>- 44 -</b>
<b>9.1</b>	<b>EC compliance statement</b> .....	<b>- 44 -</b>
<b>9.2</b>	<b>UKCA Declaration of Conformity</b> .....	<b>- 45 -</b>
<b>9.3</b>	<b>Technical data</b> .....	<b>- 46 -</b>
<b>9.4</b>	<b>Dimensions sheet</b> .....	<b>- 47 -</b>
<b>9.5</b>	<b>Spare parts and accessories</b> .....	<b>- 48 -</b>

# **1 General**

## **1.1 Introduction**

This manual is an essential aid for the proper and safe operation of the product.

These operating instructions contain important information to ensure safe, proper and efficient operation of the product. Observing these instructions helps avoiding danger, reducing repair costs and downtimes and increasing the reliability and service life of the product. The operating instructions must be kept available at all times and have to be read and applied by every person who is assigned to work on or with the product.

These include amongst others:

- the operation and troubleshooting during operation
- the maintenance (care, maintenance, repair)
- the transport
- the assembly
- the disposal

Technical modifications and errors expected.

## **1.2 References to copyright and industrial property rights**

These Operating Instructions should be kept confidential. They should be made accessible only to authorised persons. They may be passed on to third parties only with the written consent from KEMPER GmbH, referred to as manufacturer in the following.

All documents are protected under the Copyright Act. The reproduction and distribution of documents, including excerpts, as well as re-use and passing on of their contents is not permitted. Unless this is expressly permitted in writing.

Violations are liable to prosecution and liable for damages. The manufacturer reserves the right to exercise all intellectual property rights.

## **1.3 Notes for the operating company**

The operating instructions are an essential part of the product.

The operating company must ensure that the operating personnel is aware of the contents of this manual.

Based on national regulations for accident prevention and environmental protection, the operating instructions are to be supplemented by the operating company's own operating instructions, including information on regulatory and reporting requirements to meet specific operating requirements, such as work organisation, work flow and staff employed. In addition to the operating instructions and the relevant obligatory

regulations for accident prevention applicable in the country of use, it is also imperative to comply with the recognised technical rules for safe and professional handling.

Without prior consent from the manufacturer, the operating company may not carry out any changes, conversions or additions to the product which may impair safety. Spare parts used must comply with the manufacturer's specified technical requirements. This is always the case with original replacement parts.

Only use trained and instructed staff for the operation, maintenance, repair and transport of the product. Clearly define for staff who is responsible for operation, maintenance and transport.

## 2 Safety

### 2.1 General information

The product is designed and built according to state-of-the-art technology and the recognised safety rules and regulations. When operating the product, technical hazards for the operator or impairment of the product as well as other property may occur, if:

- it is not operated by trained or instructed personnel
- it is not used for the purpose intended and/or
- it is improperly maintained

### 2.2 Information on signs and symbols

#### **▲ DANGER**

This symbol in conjunction with the signal word "Danger" indicates imminent danger. Non-adherence of the safety note leads to death or serious injuries.

#### **▲ WARNING**

The symbol in conjunction with the signal word "Warning" indicates a potentially dangerous situation. Non-adherence to the safety notice may lead to death or serious injuries.

#### **▲ CAUTION**

The symbol in conjunction with the signal word "Caution" indicates a potentially dangerous situation. Non-adherence of the safety note may lead to slight or negligible injuries.

May also be used for warnings against property damage.

#### **NOTE**

The general information is simple additional information which does not warn about personal injury or property damage.

1. Enumerations of action steps are marked as numbers with a dot, where the order is important.
- Bullet points indicate lists of parts in a legend or instructions for which the sequence is unimportant

## **2.3 Markings/signs to be affixed by the operating company**

The operating company is obliged to post further markings and signs on the product and the surrounding area if necessary.

Such markings and signs might be related, for example, to the requirement for wearing personal protective equipment.

## **2.4 Safety instructions for operating staff**

Before use, the operator of the product must be instructed through information, instructions and training on the handling of the product and the materials and aids to be used.

The product system may only be used in technically perfect condition, for its intended purpose, in full awareness of the safety aspects and potential dangers and in accordance with these instructions. All errors, especially those that may affect safety, must be removed immediately.

Every person who is charged with commissioning, operation or maintenance must have fully read and understood these operating instructions. This specifically applies to staff who only operate the product occasionally.

The operating instructions must always be within reach of the product.

We accept no liability for any damages or injuries caused by failure to observe these operating instructions.

The relevant accident prevention regulations and other generally recognised safety and occupational health regulations must be observed.

The responsibilities for the various activities included in maintenance and repair must be clearly defined and adhered to. Only then will human error - especially in dangerous situations - be avoided.

The operating company is to enforce wearing of personal protective equipment by operating and maintenance staff. These include in particular safety shoes, safety glasses and gloves.

Do not wear loose, long hair, loose clothing or jewellery. In theory, there is a risk of getting caught on something, or being pulled in or dragged along by moving parts.

If there are any safety-related changes to the product, immediately halt the process, secure it and report the occurrence to the relevant authority/person!

Work on the product may only be carried out by reliable, trained staff. Observe the minimum legal age.

Staff who require training, teaching or instructing or staff who undergo a general apprenticeship may only operate the product under the supervision of an experienced member of staff.

## 2.5 Safety instructions for maintenance/troubleshooting

Service and maintenance doors must be freely accessible at all times.

Setting up, maintenance and repair work and troubleshooting must only be performed when the product is switched off.

Always tighten bolt connections that have been loosened during repair work. If specified, tighten the relevant bolts with a torque wrench.

In particular, protect connections and screw connections from dirt or care products at the beginning of maintenance/repair/care

The time frames for periodic testing/inspections stipulated or specified in the operating instructions must be observed.

Before disassembling, mark the parts that belong together.

## 2.6 Notes regarding special types of hazard

### **⚠ DANGER**

#### **Danger of electric shock!**

Any work on the electrical equipment of the product must only be performed by a qualified electrician or by operating personnel under the direction and supervision of a qualified electrician in accordance with electronic regulations.

Before opening the product, pull the plug, if available, and secure it against accidental switch-on.

For faults with the product's electrical energy supply, immediately switch the product off at the on/off switch and if available, also pull the plug.

Use only original fuses with the prescribed amperage.

Electrical components, on which inspection, maintenance and repair work must be carried out, must be disconnected from the power supply. Secure equipment that has been used for disconnection against unintentional or automatic reconnection. Firstly check that no voltage is present in activated, electrical components, then isolate adjacent components under voltage. When making repairs, ensure that constructive characteristics are not altered in a way that reduces safety.

Check cables regularly for damage and replace if necessary.

**⚠ WARNING****Electric shock if earthing is missing!**

If the protective earth connection of devices is missing or incorrectly executed, high voltages may be present on exposed parts or housing parts which, if touched, can lead to serious injury or death.

**⚠ WARNING****Electric shock if an unsuitable power supply is connected!**

The connection of an unsuitable power supply can cause parts that can be touched to be under dangerous voltage. Contact with dangerous voltage can lead to serious or fatal injury.

For electrical connection data, see the name plate of the product

**Power supply**

The product is designed for the mains voltage indicated on the name plate. If mains cables or mains plugs are not fitted to the product, they must be fitted in accordance with national standards.

**⚠ CAUTION****Insufficiently dimensioned electrical installation can lead to serious damage to property.**

The mains supply line and its fuse protection must be designed in accordance with the existing power supply. Observe the technical data on the name plate.

The mains fuse should be equipped with at least a **category C** circuit breaker.

**⚠ DANGER****Suspended loads**

Tipping or falling loads lead to severe to fatal injuries.

- Never step under suspended loads.
- Always remain outside the danger zone.
- Observe the total weight, attachment points and centre of gravity of the load.
- Observe the transport instructions and symbols on the transported goods.

**⚠ WARNING****Health hazards caused by welding fume particles**

Do not inhale welding dust / smoke! Serious injury to the lungs and respiratory tract is possible!

Sweat smoke contains substances that can cause cancer!

Skin contact with cutting and welding fumes etc. can cause skin irritation in sensitive persons!

Repair and maintenance work on the product may only be carried out by trained and authorised personnel while complying with the safety rules and the applicable accident prevention regulations.

To avoid contact with and inhalation of the dust particles, wear disposable overalls, protective goggles, gloves and a suitable Class FFP2 respiratory protection filter mask in accordance with EN 149.

The release of hazardous dust particles during repair and maintenance is to be avoided to ensure that persons not charged with the task are not affected.

**⚠ CAUTION****Health hazard due to noise!**

The product can produce noise, please refer to information in the technical data. In connection with other machines and/or local conditions, a higher noise level can occur at the operation site of the product. In this case, the operating company is obliged to provide the operating personnel with the appropriate protective equipment.

### 3 Product information

#### 3.1 Functional description

The product is a compact welding fumes filter device that extracts welding fumes at the point where they are produced and extracts them with a filter efficiency of more than 99%.

The extracted contaminated air is cleaned using a 1-stage filter method and then fed back into the workspace.

The product is equipped with a flexible extraction arm that is available in different lengths from the manufacturer.

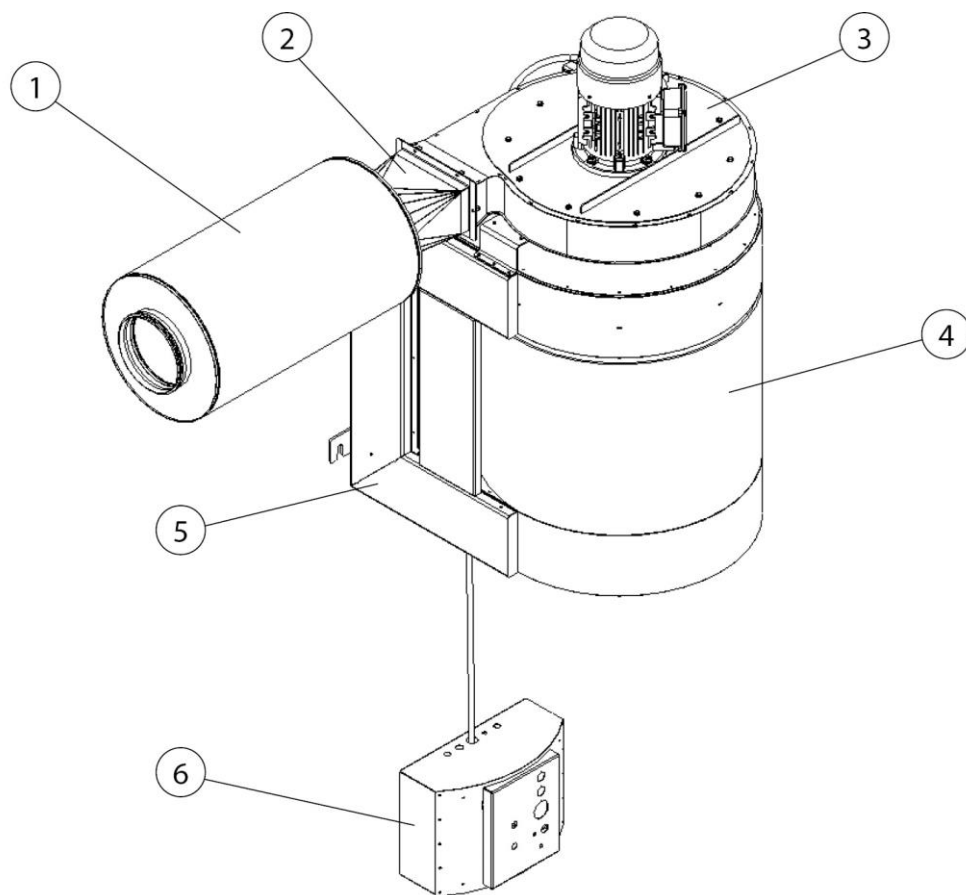

*Fig. 1: Positions on the product*

Pos.	Description	Pos.	Description
1	Silencer	4	Filter element
2	Adapter	5	Device frame
3	Fan	6	Control box

*Tab. 1: Positions on the product*

### 3.2 Distinguishing feature – W3 certified

The product is manufactured in two versions:

- **Version – non W3 certified**
- **Version – W3 certified**

**Attention**

Only products labelled with the W3 sticker have been tested and certified accordingly.

See also chapter technical data: Welding fume class and test standard.

**W3-tested:**

The product has been tested by the IFA (Institute for Occupational Safety and Health of the German Social Accident Insurance Institutions). It fulfils the requirements of welding fume separation class W3 and conforms to EN ISO 21904-1.

The tested products are labelled with the DGUV test mark and a W3-tested (marking of the welding fume separation class) in the form of a sticker.

Labelling on the product	Meaning/explanation	Reference logo
W3 sticker	Type "W3 certified" according to test standard – see chapter "Technical data"	

*Tab. 2: W3 label*

### 3.3 Intended use

The product is designed to extract and filter out the welding fumes produced when welding metallic materials at the point of origin. In general, the product can be used for all work processes in which welding fumes are released. However, care must be taken that no glowing sparks are drawn into the product.

Dimensions and further product details that must be observed can be found in the technical data.

---

**NOTE**

---



Only products labelled with the W3 sticker have been tested and certified accordingly. See also chapter Technical data: Welding fume class and test standard.

---

---

**NOTE**

---

When welding alloyed or high-alloy steels with filler metals above 5% chromium/nickel, carcinogenic CMR substances (carcinogenic, mutagenic, reprotoxic) are released. In accordance with official regulations, only tested and approved products may be operated in Germany to extract these harmful smoke particles using the so-called recirculation method.

Only products that meet the requirements of welding fume separation class W3/IFA certified may be operated for the aforementioned welding processes using the recirculation method.

When extracting welding fumes with carcinogenic components (e.g. chromates, nickel oxides, etc.), the requirements of TRGS 560 (technical rules for HAZMAT) and TRGS 528 (welding work) must be obeyed.

---

---

**NOTE**

---

The information in the "Technical data" chapter must be observed and strictly adhered to.

Intended use also includes observation of the instructions and information on

- safety
- operation and control
- maintenance and servicing

contained in this manual.

Any other use or use going beyond this is considered improper use. The company operating the product is solely responsible for any damage resulting from it. This also applies to unauthorised modifications to the product.

---

### **3.4 General requirements in accordance with DIN EN ISO 21904**

---

**NOTE**

---

Connection of ducting systems, extraction arms and hoses.

Ducting systems, extraction arms and hoses connected to the product can lead to a pressure drop and must be taken into account by the system designer or user.

The connected components must be suitable for the product and ensure the required minimum volume flow (extraction capacity).

A possible design of the ducting can be requested from the manufacturer.

The connected components must be checked regularly for proper seating, leaks and blockages.

The required extraction capacity must be checked at the central extraction element.

---

---

**NOTE**

---

Returning the air to the workplace atmosphere

In some Federal States, recirculation of air into the workplace atmosphere is not recommended or is prohibited. It may be necessary to conduct the exhaust air to the outside via a duct.

---

### **3.5 Reasonably foreseeable misuse**

No reasonable, foreseeable misuse is possible that could lead to dangerous situations with personal injury when working with the product whilst adhering to its intended use.

The operation of the product in industrial areas that do not comply with the requirements for explosion protection is not permissible.

Furthermore, the operation is prohibited for:

1. Processes that are not in the intended use list and in which the extracted air is:
  - is mixed with sparks, e.g. from grinding processes, which due to their size and quantity might lead to damage to the filter media or even to a fire;

- mixed with liquids and the resulting contamination of the air flow with vapours containing aerosols and oils;
  - mixed with highly flammable, combustible dust and/or with substances that can form explosive mixtures or atmospheres;
  - is mixed with other aggressive or abrasive dust that could damage the product and the filter elements employed;
  - is mixed with organic, toxic substances or a proportion of substances that are released when cutting the material.
2. Outdoor locations where the product is exposed to weather conditions because the product must only be installed in closed buildings. If there is an outdoor variant of the product available, this may be installed outside. Please note that additional accessories may be required for the outdoor installation.

### **3.6 Markings and signs on the product**

Various markings and signs are affixed to the product. If these are damaged or removed, please replace them immediately with new ones in the same location.

The operating company is obliged to post further markings and signs on the product and the surrounding area if necessary.

Such notes and signs might be related, for example, to the requirement for wearing personal protective equipment.

In the country of use, additional required safety instructions and pictograms can be provided by the manufacturer in accordance with applicable law.

### **3.7 Residual Risk**

Even when all safety rules are observed, when operating the product a residual risk remains, as described below.

All persons working on and with the product must be aware of these residual risks and follow the instructions that prevent these residual risks from causing accidents or damages.

**⚠ WARNING**

Danger of serious injury to the lungs and respiratory tract – always wear respiratory protection, Class FFP2 or higher.

Skin contact with welding fume particles may cause skin irritation in sensitive persons – wear protective clothing.

Before starting the welding process, ensure that the product is properly adjusted and in operation. The filter elements must be complete and in undamaged condition.

The connected detection element must reliably detect the welding fumes. For the correct positioning, refer to the documentation of the detection element.

When changing the filter inserts, skin contact with the separated dust particles may occur and parts of the dust particles may also be stirred up by the work. Respiratory protection and protective clothing must be worn.

Embers in the filter elements may cause smouldering fires – switch off the product, close the damper flap in the collection element if fitted and let the device cool down in a controlled manner.

---

## **4 Transport and Storage**

### **4.1 Transport**

#### **⚠ DANGER**

Life-threatening crushing possible when loading and transporting the product!

Improper lifting and transporting may cause the pallet (if present) to tilt and fall!

- Never stand under suspended loads.
- Observe the permissible loads of the transport and lifting aids.
- Observe the applicable accident prevention and occupational safety regulations.

For transporting products with a pallet, use a suitable pallet truck or forklift. The weight of the product can be found on the name plate.

### **4.2 Storage**

The product must be stored in its original packaging at an ambient temperature of 20 °C to +50 °C in a dry and clean place. The packaging must not be loaded by other objects.

The storage duration is not critical for all products.

## 5 Assembly

### Instructions for safe installation of the product

#### NOTE

---

The operating company of the product may only assign specialists to carry out independent assembly.

- At least two people are needed to assemble the product.
  - Only use suitable transport and lifting equipment.
  - It must be ensured that the assembly location provides sufficient load-bearing capacity.
  - Only use suitable fixing material.
  - The fixing material must be selected according to the local conditions.
  - The product must not obstruct anyone in their working area.
  - Existing air outlet grilles must not be covered.
  - Existing maintenance doors and covers must be freely accessible.
- 

#### **⚠ DANGER**

---

#### **Falling parts may cause life-threatening injuries!**

Tipping or falling loads lead to severe to fatal injuries.

- Never step under suspended loads.
  - Always remain outside the danger zone.
  - Observe the total weight, attachment points and centre of gravity of the load.
  - Observe the transport instructions and symbols on the transported goods.
- 

#### **⚠ WARNING**

---

#### **Incorrect connections may cause serious injuries!**

Please note the necessary safeguards and only have the product connected by trained specialists.

---

**NOTE**

Ensure that the welding current return line between the workpiece and the welding machine has a low resistance and that connections between the workpiece and the product are avoided so that the welding current cannot flow back to the welding machine via the product's protective conductor.

**5.1 Unpacking the product**

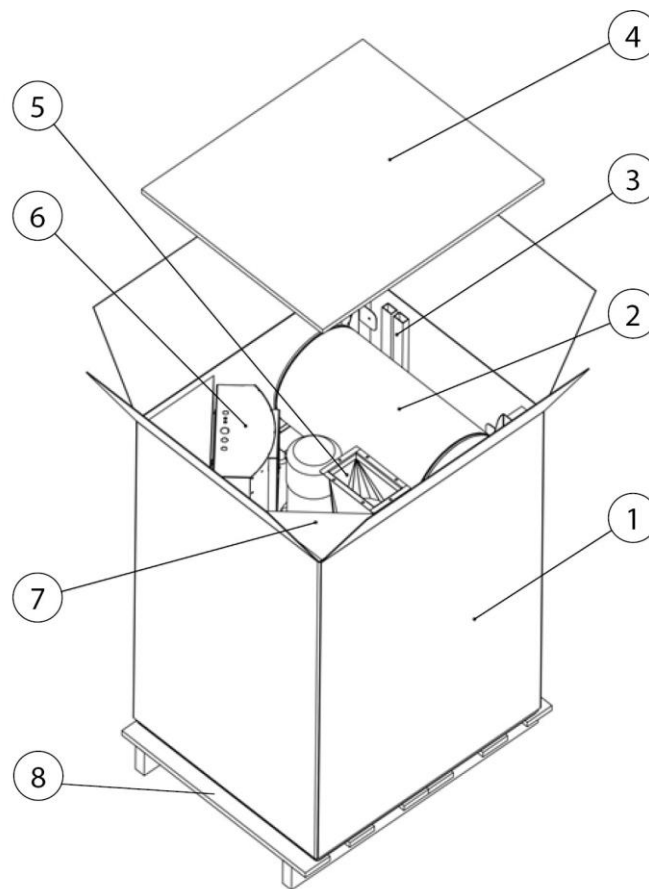

*Fig. 2: Unpacking the product*

Pos.	Description	Pos.	Description
1	Outer packaging	5	Adapter
2	Silencer	6	Control box
3	Cable duct (2x)	7	Edge protection profile
4	Lid plate	8	Pallet

*Tab. 3: Positions on the product*

Unpacking is carried out as follows:

1. Open the lid of the outer packaging (Pos. 1) and remove the lid plate (Pos. 4).
2. Remove the control box (Pos. 6), the adapter (Pos. 5), the silencer (Pos. 2) and the two cable ducts (Pos. 3).
3. Remove the edge protection profiles (Pos. 6) and remove the outer packaging (Pos. 1) from the product.

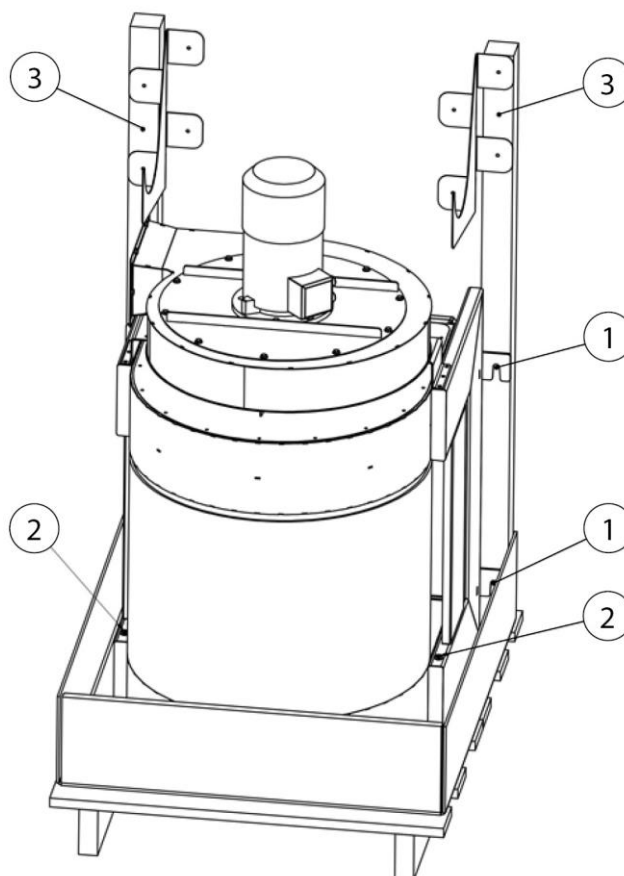

Fig. 3: Unpacking the product

Pos.	Description	Pos.	Description
1	Wood screws	3	Square timber
2	Locking screws		

Tab. 4: Positions on the product

1. Unscrew the four wood screws (Pos. 1) and remove the square timber.
2. Remove the two locking screws (Pos. 2), then remove the plastic bag from the product.

## 5.2 Installation of the product

Carry out the assembly of the product as follows:

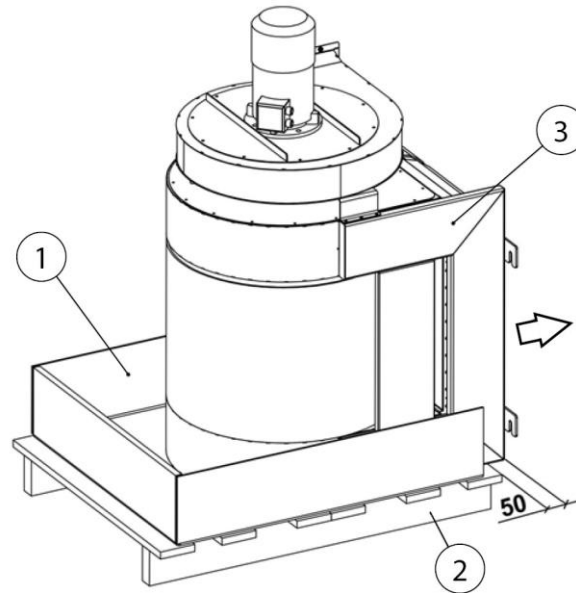
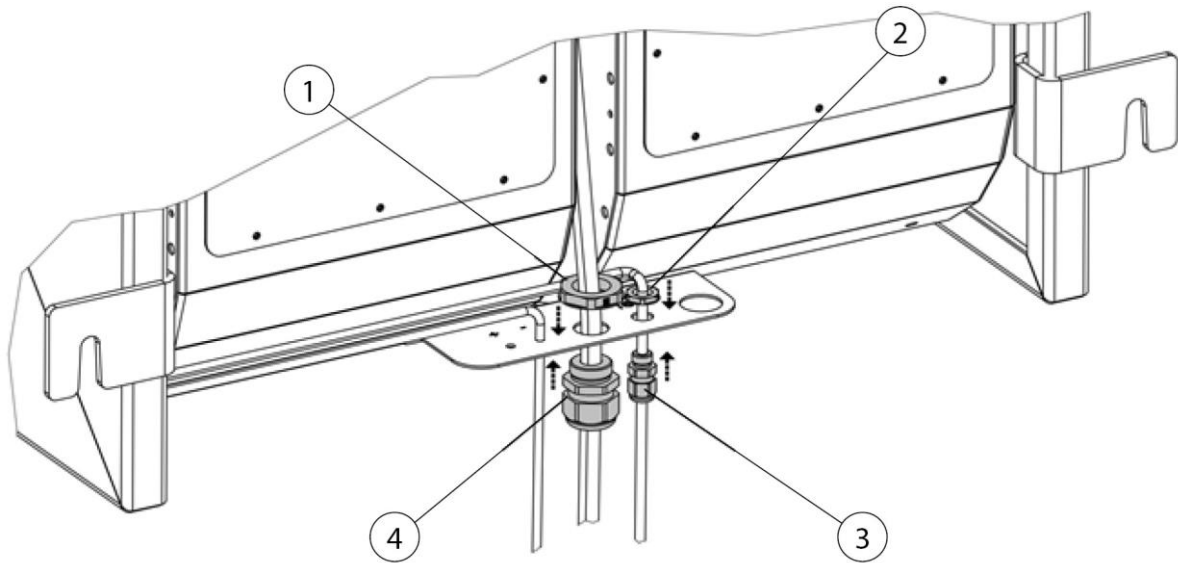

Fig. 4: Installation of the product

Pos.	Description	Pos.	Description
1	Cardboard bottom	3	Product
2	Pallet		

Tab. 5: Positions on the product

1. Cut off the back carton edge of the cardboard bottom (Pos. 1).
2. Pull the product (Pos. 3) approx. 5 cm backwards over the pallet (Pos. 2).

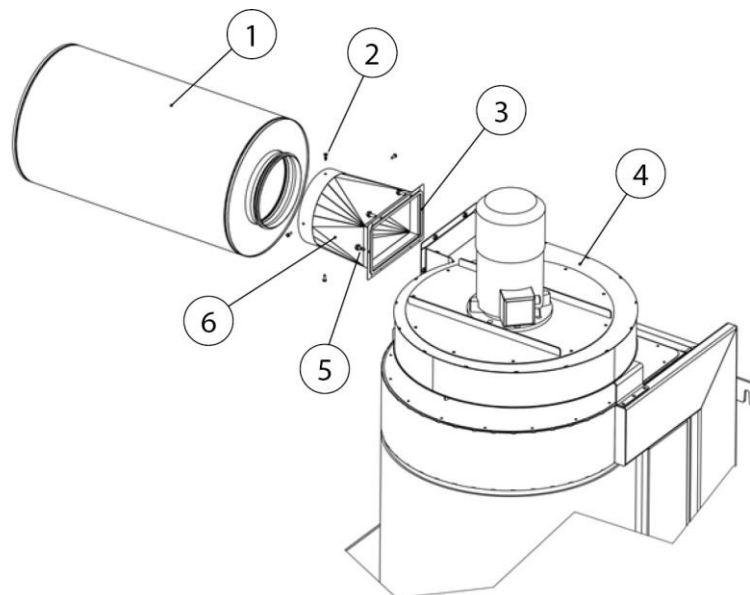

*Fig. 5: Attaching the cable glands*

Pos.	Description	Pos.	Description
1 + 2	Locknut	3 + 4	Bolt connection

*Tab. 6: Attaching the cable glands*

3. Mount the two cable glands (Pos. 3 + 4) with the two locknuts (Pos. 1 + 2) according to the figure.



*Fig. 6: Mounting the silencer*

Pos.	Description	Pos.	Description
1	Silencer	4	Fan
2	Drilling screw (4x)	5	Hex bolt (6x)
3	Adapter flange	6	Adapter

Tab. 7: Positions on the product

4. Stick the enclosed seal onto the adapter flange (Pos. 3), do not cover the bore holes.
5. Screw the adapter (Pos. 6) onto the fan (Pos. 4) using the hex bolts (Pos. 5).
6. Insert the silencer (Pos. 1) onto the adapter (Pos. 6) and fix in place with the drilling screws (Pos. 2).

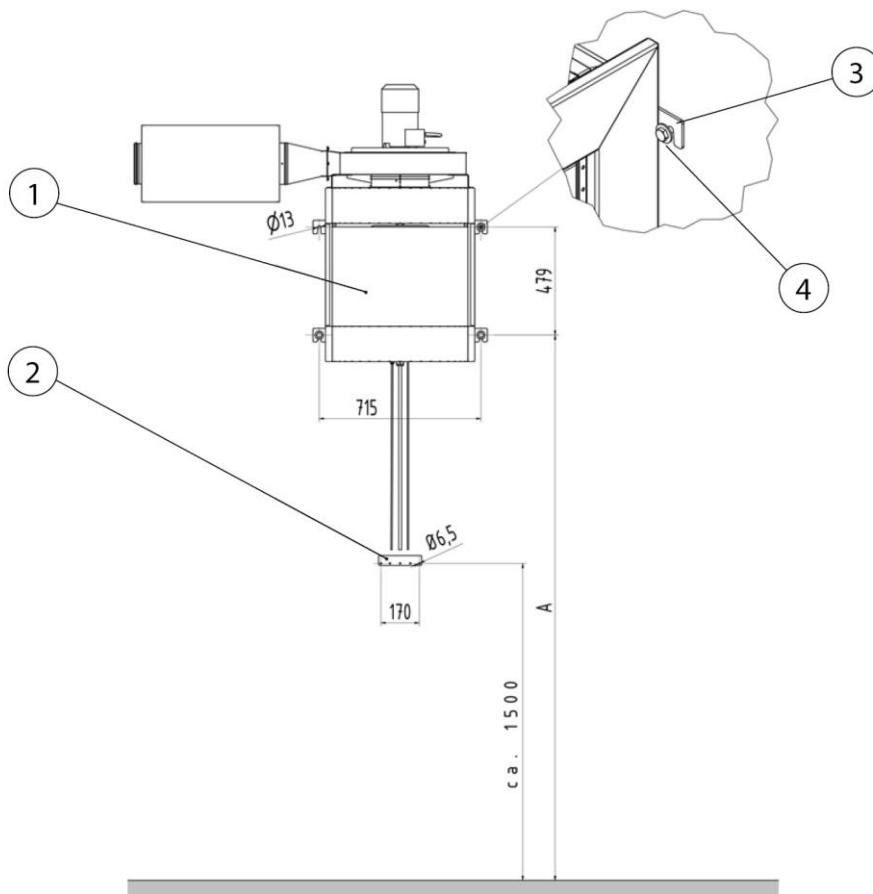

Fig. 7: Determining the mounting height

Pos.	Description	Pos.	Description
1	Product	3	Support points (product)
2	Control box mounting point	4	Fixing material (fixing screws)

*Tab. 8: Positions on the product*

Extraction arm length	Note	A [mm]
2 m, 3 m, 4 m	-	2420
5 m, 6 m, 7 m	With wall bracket art. no.: 9113004	3070
7 m, 8 m	With cantilever 4 m, art. no.: 7911407	3310
9 m, 10 m	With cantilever 6 m, art. no.: 7911607	3510

*Tab. 9: Determining the mounting height*

7. At the installation location, determine the required mounting height of the product according to the table. The required mounting height depends on the extraction arm selected.
8. Drill the four bore holes according to the figure. Use a spirit level for alignment.
9. Insert suitable fixing material into the bore holes so that the product can be securely hooked onto the support points (Pos. 3).
10. Lift the pallet with the product using a suitable lifting tool and attach it to the fixing material using the four support points.
11. Tighten the four fixing screws and make sure that the product is securely held.

**Mounting the control box**

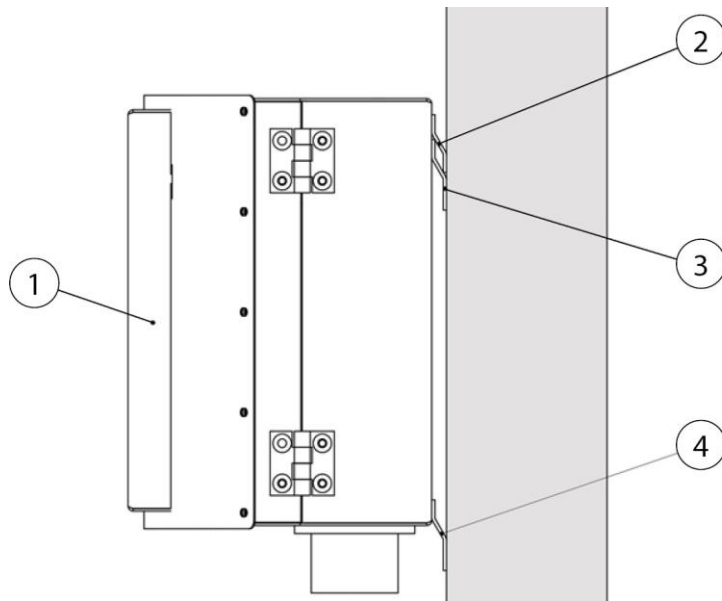

*Fig. 8: Mounting the control box*

Pos.	Description	Pos.	Description
1	Control box	2, 3, 4	Brackets

*Tab. 10: Positions on the product*

Carry out the mounting of the control box as follows.

1. Mount the bracket (Pos. 3) for the control box (Pos. 1) at the installation location under the product using suitable fixing material, paying attention to the mounting height. (see figure: Determining the mounting height)
2. Hook the control box (Pos. 1) with the bracket (Pos. 2) into the bracket (Pos. 3).
3. Mark the bore holes for the bracket (Pos. 4). Then remove the control box (Pos. 1) and drill the previously marked bore holes.
4. Hook the control box (Pos. 1) back into the bracket (Pos. 3) and fix the bracket (Pos. 4) in place with suitable fixing material.

**Connecting the product**

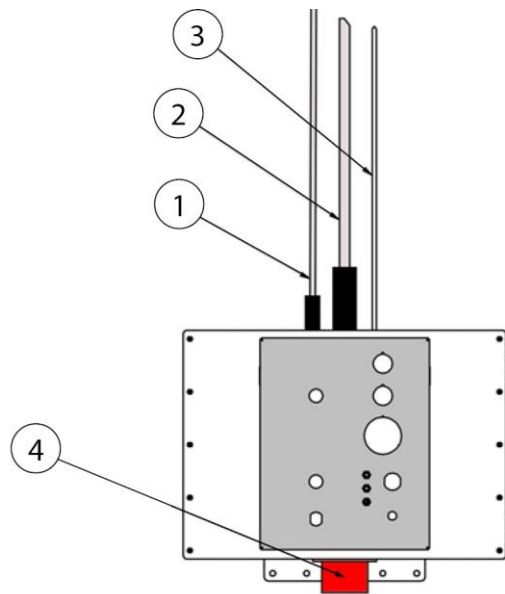

*Fig. 9: Connecting the product*

Pos.	Description	Pos.	Description
1	Cable for lighting + on/off of the extraction hood	3	Measuring hose
2	Motor lead	4	Power supply connection (CEE connection socket)

*Tab. 11: Positions on the product*

1. Plug the connector of the lighting cable (Pos. 1) into the appropriate connection socket of the control box.

**NOTE**

Cable for lighting + on/off of the extraction hood (Pos.1)

If an extraction arm without lighting + on/off is mounted on the product, the dummy plug (bridge) included in the scope of supply must be plugged into the connection socket provided.

2. Plug the connector of the motor cable (Pos. 2) into the appropriate connection socket of the control box.
3. Plug the measuring hose (Pos. 3) onto the connecting sleeve of the control box.

4. To protect the cables and the measuring hose (Pos. 1 – 3), mount the supplied cable duct on the wall/column, taking care not to damage the connection lines.
5. Connect the on-site power supply cable to the CEE connection socket (Pos. 4) of the control box (Pos. 1).

**Assembling the extraction arm**

To assemble the extraction arm, follow the enclosed instructions.

## 6 Use

Every person who deals with use, maintenance and repair of the product must have thoroughly read these operating instructions as well as the instructions for any attachment and accessory products and have understood them.

### 6.1 Qualification of the operating personnel

The operating company of the product may only commission persons to use the product independently if they are well-versed in this task.

Those familiar with this task includes those who have been instructed appropriately in the task and know the operating instructions as well as the operational issues in question.

The product should only be used by trained or instructed personnel. This is the only way to ensure safety and hazard awareness of all personnel during work.

### 6.2 Operating elements

The product is equipped with a compact control unit (control box).

The operating interface is set up as follows:

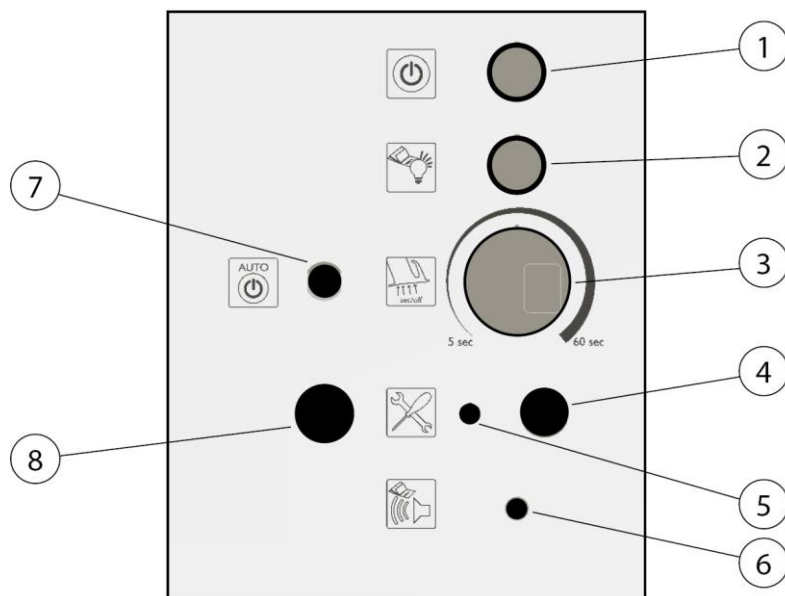

*Fig. 10: Operating control*

<b>Pos.</b>	<b>Description</b>	<b>Function</b>
1	Device button with power light	Switches the product on or off
2	Signal light	Signals the operation of the product
3	Rotary regulator for run-on time in start/stop operation	For setting the desired run-on time of the fan
4	Maintenance socket	For service personnel only
5	Connection for pressure measurement	For service personnel only
6	Signal horn	
7	Connector socket for start-stop sensor	
8	Pressure switch	For service personnel only

*Tab. 12: Operating control*

### **6.3 Positioning the extraction hood**

The extraction arm or extraction hood is designed in such a way that it can be adjusted and moved easily by hand. Once it has been positioned, the extraction hood maintains its set position of its own accord. Furthermore, both the extraction hood and the arm can be pivoted through 360° so that almost any position can be set. It is important that the extraction hood is always positioned properly in order to achieve adequate capture of the welding fumes. The correct position is shown on the following image.

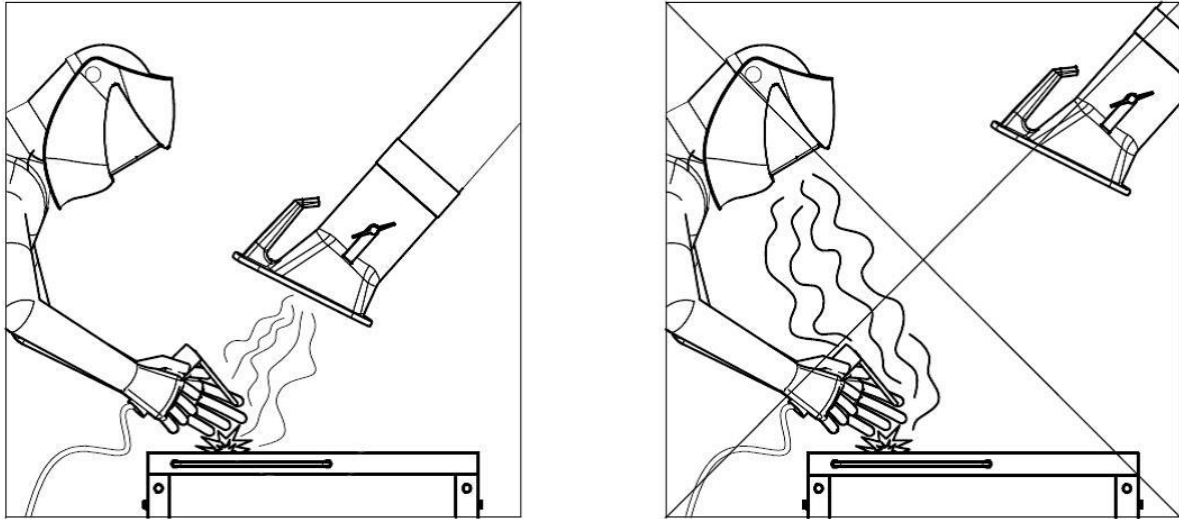

Fig. 11: Positioning the extraction hood

- Position the extraction arm so that the extraction hood is located approx. 25 cm diagonally above the weld.
- The extraction hood must be positioned so that it safely captures the welding fumes, taking into account the movement of welding fumes caused by the heat and the extraction range.
- Always move the extraction hood with respect to the weld position as you advance.

#### **▲ WARNING**

An incorrectly positioned extraction hood or too low an extraction capacity do not ensure that air containing hazardous substances is captured adequately by the extraction hood. This means hazardous substances can enter the area where the operating personnel breathes and cause severe damage to health.

## 6.4 Commissioning

#### **▲ WARNING**

Danger due to faulty product condition.

The product must be fully installed before commissioning begins. All doors must be closed and the necessary connections must have been made.

1. Ensure that the product is supplied with power.

2. Switch the product on using the pushbutton marked "0" and "I".
3. The fan starts and the green indicator lamp on the device switch indicates error-free operation.

In the event of a malfunction, the signal lamp lights up (see chapter "Troubleshooting").

## **7 Maintenance**

The instructions in this chapter are intended as minimum requirements. Depending on the operating conditions, further instructions may be required to keep the product in optimal condition.

The maintenance and repair work described in this chapter must only be performed by specially trained repair personnel of the operating company.

Spare parts used must comply with the manufacturer's specified technical requirements.

This is guaranteed if original spare parts are used.

The safe and environmentally friendly disposal of operating materials and replacement parts must be ensured.

The safety instructions in these operating instructions must be observed during maintenance work.

### **7.1 Care**

The care of the product is essentially limited to cleaning all surfaces of the product and – if present – checking the filter inserts.

The warning notices listed in the chapter "Safety notes for maintenance and fault removal" must be observed.

---

#### **NOTE**

The product may not be cleaned with compressed air. This may result in dust and/or dirt particles getting into the ambient air.

---

Proper care helps to maintain the product in a continuous functional state.

For optimum care and cleaning of the powder-coated surfaces, the following must be observed:

- Thoroughly clean the product monthly or as needed.
- Clean the exterior areas of the product with a suitable industrial vacuum cleaner of dust classification H or with damp soft cloths/industrial cotton wool.
- For stubborn dirt, use commercially available household cleaners. Avoid vigorous rubbing.
- Do not use any abrasive agents that scratch.
- Do not use any acidic or strongly alkaline cleaning agents.
- Do not use organic solvents containing esters, ketones, alcohols, hydrocarbons or similar.

## 7.2 Maintenance

Regular inspection and servicing have a positive effect on the reliable functioning of the product and should be carried out at least once a year.

Except for the necessary filter replacements, the product operates maintenance-free.

Observe the warning notices for servicing and troubleshooting in the "Safety" chapter.

## 7.3 Maintenance

### NOTE

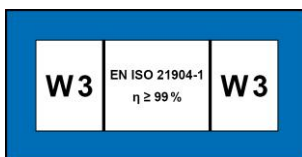

If the product is labelled with the W3 sticker, the product has IFA approval and has been tested in accordance with the requirements of welding fume separation class W3.

#### **The IFA approval becomes void if:**

- The product is used other than as intended or is subject to constructive modifications.
- Non-original spare parts, in accordance with the spare parts list, are used.

The quality standard can only be guaranteed if original spare parts are used.

The manufacturer accepts no liability for damage caused by the use of non-original parts.

All maintenance work must be recorded in the maintenance logbook.

### 7.3.1 Changing the filter – Safety instructions

The life of the filter inserts depends on the type and amount of deposited particles.

As the dust accumulation in the filter increases, its flow resistance increases and the extraction capacity of the product decreases.

Even with products that may have automatic filter cleaning, adhering deposits can reduce the extraction capacity.

A filter change is required.

**⚠ WARNING**

Health hazards caused by welding fume particles

Do not inhale welding dust / smoke! Serious injury to the lungs and respiratory tract is possible!

Sweat smoke contains substances that can cause cancer!

Skin contact with welding fume particles can cause skin irritation in sensitive individuals.

To avoid contact with and inhalation of these dust particles, wear disposable overalls, protective goggles, gloves and a suitable Class FFP2 respiratory protection filter mask in accordance with EN 149.

**⚠ WARNING**

Cleaning the filter inserts is not permitted. This inevitably leads to damage to the filter element, meaning the filter ceases to function and hazardous substances enter the air.

During the work described in the following section, pay particular attention to the seal on the main filter. Only an undamaged seal allows the product to achieve a high filter efficiency. Main filters with a damaged seal must therefore be replaced every time.

---

**NOTE**

---

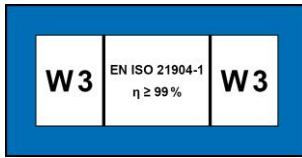

Products with W3 certification according to requirements for W3/IFA certified welding fume separation class. (See "Technical data" chapter)

**The W3 approval becomes void if:**

- The product is used other than as intended or is subject to constructive modifications.
- Non-original spare parts, in accordance with the spare parts list, are used.

- 
- Only original replacement filters, because they guarantee the necessary filter efficiency and are matched to the product and its performance characteristics.
  - Switch the product off using the on/off switch.
  - Secure the product against unintentional switching on. If available, pull out the mains plug or secure the main switch in the 0 position with a padlock.
  - Disconnect the pressure supply, if present, and let the compressed air present in the product flow out via the condensate drain valve.

### 7.3.2 Changing filters

A suitable hoist with platform or a scaffold is required for the filter change so that the service personnel can carry out the filter change safely.

Perform the filter change as follows:

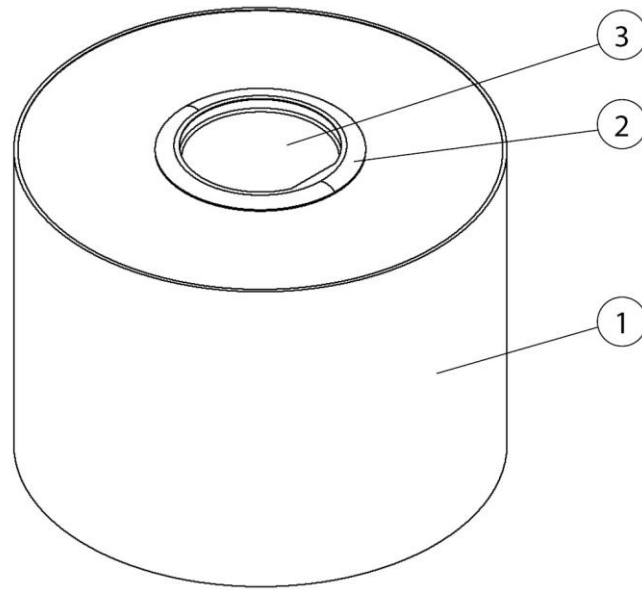

*Fig. 12: Filter change – Providing a new filter element*

Pos.	Description	Pos.	Description
1	Filter element	3	Sealing cap
2	Gasket ring		

*Tab. 13: Filter change – Providing a new filter element*

**Changing the filter element:**

1. Switch the product off at the device switch.
2. Prevent unintentional restarting by disconnecting the mains plug.
3. Remove the new filter element (Pos. 1) from the box and remove the sealing cap (Pos. 3). Ensure the sealing ring (Pos. 2) is not damaged in the process.

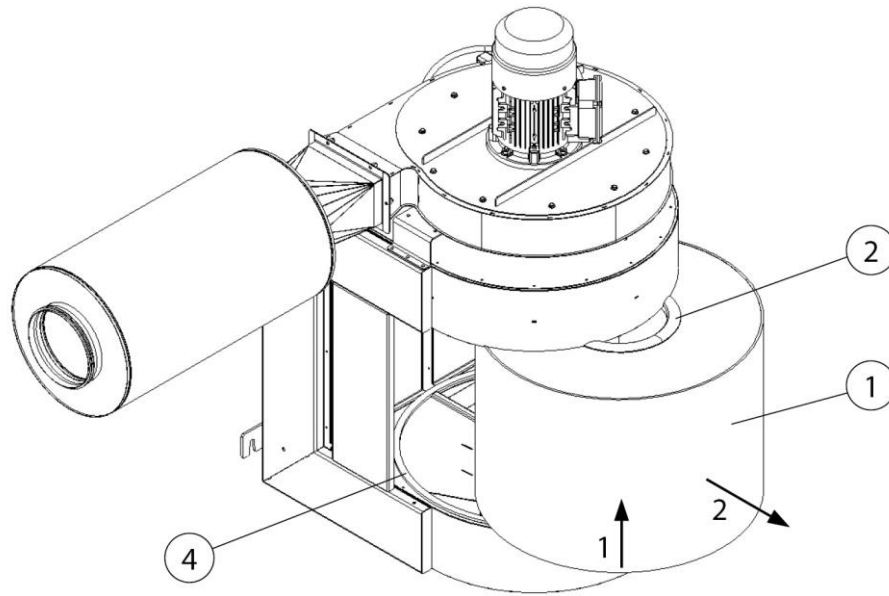

Fig. 13: Carrying out a filter change

Pos.	Description	Pos.	Description
1	Filter element		
2	Sealing ring	4	Mounting

Tab. 14: Carrying out a filter change

4. Lift the saturated filter element (Pos. 1) slightly out of the mounting (Pos. 4) and carefully remove from the product.

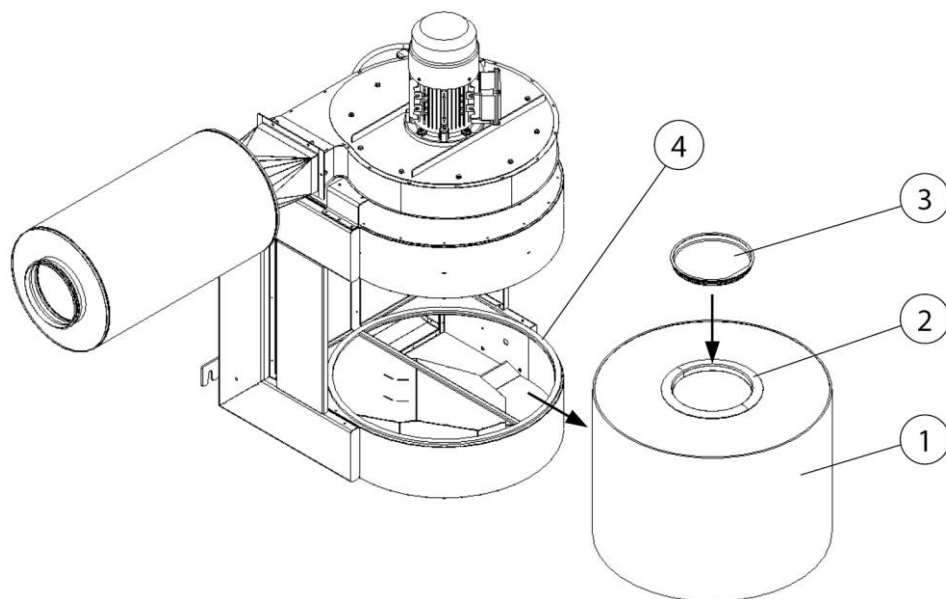

Fig. 14: Carrying out a filter change

5. Seal the saturated filter element (Pos. 1) with the sealing cap (Pos. 3) of the new filter element.
6. Then dispose of the saturated filter element in accordance with current regulations.

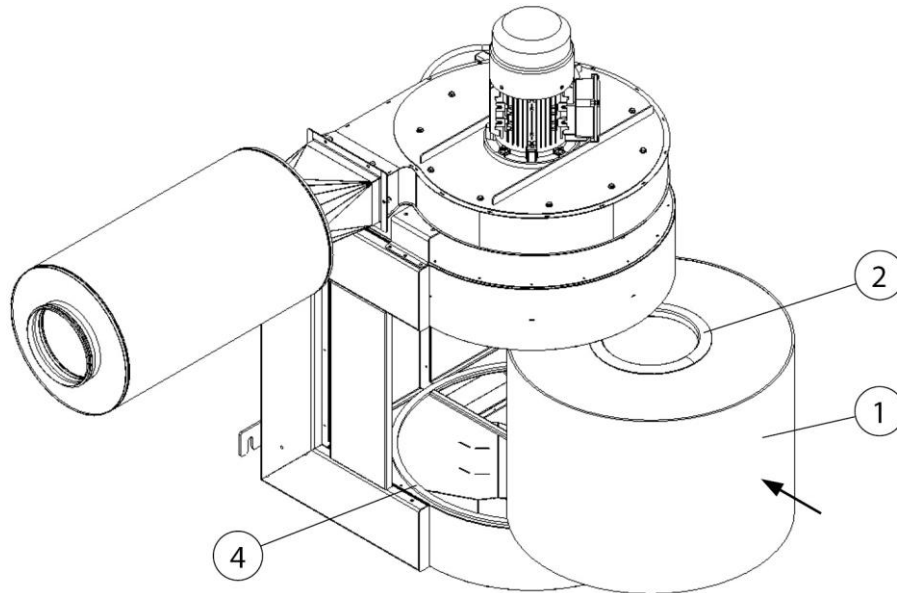
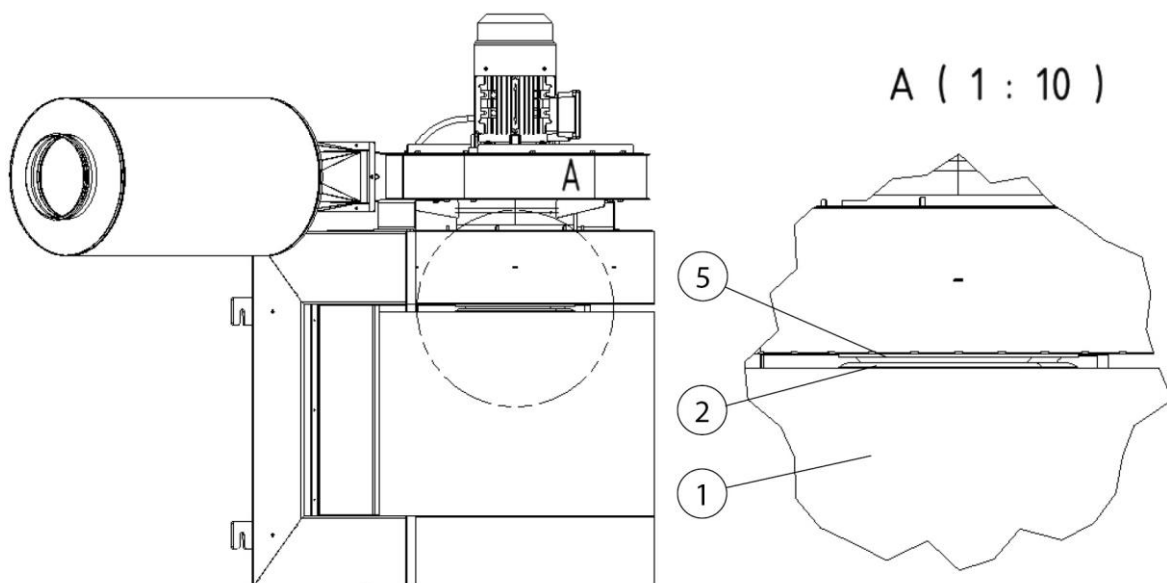

Fig. 15: Carrying out a filter change

7. Push the new filter element back into the product mounting (Pos. 4) in reverse order. Ensure the sealing ring (Pos. 2) does not rub against the sealing surface (Pos. 5) and is not deformed or destroyed.



*Fig. 16: Filter change – Checking the seal*

8. Connect the product to the power supply and put it into operation, see chapter Commissioning.

### 7.4 Troubleshooting

<b>Fault</b>	<b>Possible cause</b>	<b>Note</b>
Green illuminated ring around the on/off switch does not light up.	No power supply available	Have the power supply checked by a qualified electrician
Product does not start	No power supply available	Have the power supply checked by a qualified electrician
	Cable for lighting + on/off not connected or dummy plug not plugged in.	Dummy plug only for extraction arm without lighting + on/off function
Yellow signal lamp flashes at regular intervals	Product maintenance is due	Contact manufacturer's service department
Yellow signal lamp flashes briefly twice in a row at regular intervals	Motor protection has tripped	Let the product cool down, Clean engine cooling air intake grille
Yellow signal lamp flashes briefly twice in a row at regular intervals	Rotary field error	Have the rotary field checked by a qualified electrician
Signal horn sounds	The set minimum extraction rate has not been reached. Filter inserts saturated, piping/extraction system closed off	Filter change required, check piping/extraction system, contact service
		 <p>Requirements are no longer met!</p>
Dust particles escape on the clean air side	Filter insert damaged	Change filter insert Contact the manufacturer's service department

*Tab. 15: Troubleshooting*

**NOTE**

---

If the fault cannot be corrected by the customer, please contact the manufacturer's service department.

---

**7.5 Emergency measures**

In case of fire of the product or its detection elements, the following steps should be taken if necessary:

1. Disconnect the product from the mains! If present; pull out mains plug; set main switch to 0-position; disconnect supply fuses.
2. If present, disconnect the compressed air supply.
3. Fight fire with a commercially available dry powder extinguisher.
4. Notify local fire brigade if necessary.

**▲ WARNING**

---

Do not open products with maintenance door. Flash flame formation!

In the event of a fire, do not touch the product under any circumstances without proper protective gloves. Risk of burns!

---

## **8 Disposal**

### **▲ WARNING**

Skin contact with welding fumes, etc. can cause skin irritation in susceptible individuals.

Disassembly work on the product may only be carried out by trained and authorised personnel while complying with the safety rules and the applicable accident prevention regulations.

Serious injury to the lungs and respiratory tract is possible!

In order to avoid contact with and inhalation of dust particles, use protective clothing, gloves and a blower respirator system.

The release of hazardous dust particles must be avoided during dismantling work so that persons in the vicinity are not harmed.

### **▲ CAUTION**

All work on and with the product must comply with the legal obligations for waste avoidance and proper recycling/disposal.

### **8.1 Plastics**

Plastics, if present, must be sorted as far as possible. Plastics must be disposed of in compliance with the legal requirements.

### **8.2 Metals**

Metals, if present, must be separated and disposed of. Disposal must be carried out by an authorised company.

### **8.3 Filter elements**

Filter elements, if present, must be disposed of in compliance with the legal requirements.

## 9 Annex

### 9.1 EC compliance statement

Designation:	Welding fume filter unit
Series:	MaxiFil stationär
Type:	<b>65850</b> (if necessary, different item numbers for other product variants)
Machine ID:	See name plate in front section of this operating manual This product is developed, designed and manufactured in accordance with EC directives 2006/42/EC – Machinery Directive  The product continues to comply with the provisions of the 2014/30/EU – EMC Directive 2014/35/EU – Low Voltage Directive 2011/65EU – RoHS Directive
Company:	At the sole responsibility of <b>KEMPER GmbH</b> Von-Siemens-Str. 20, D-48691 Vreden

The following harmonised standards are used:

- EN ISO 12100:2010 Safety of machinery - General principles for design
- EN ISO 13857:2019 Safety of machinery - Safety distances
- EN ISO 13854:2019 Safety of machinery - Minimum gaps
- EN ISO 21904-1:2020 Health and safety in welding and allied processes
- EN IEC 61000-6-2:2019 Electromagnetic compatibility (EMC) - Part 6-2: Generic standards - Immunity standard for industrial environments
- EN IEC 61000-6-4:2019 Electromagnetic compatibility (EMC) - Part 6-4: Generic standards - Emission standard for industrial environments
- EN 60204-1:2018 Safety of machinery - Electrical equipment of machines
- EN ISO 13849-1:2015 Safety of machinery - Safety-related parts of control systems

A complete list of standards, directives and specifications applied is available from the manufacturer. The operating manual belonging to the product is available.

Additional information:

If it is not used for as intended or the design is altered, the Declaration of Conformity expires, unless confirmed in writing by us as manufacturers.

Mr Marcel Kusche is authorised to compile the technical documentation. Kemper GmbH, Von-Siemens-Str. 20, 48691 Vreden, Germany

Vreden, 29.04.2025

Place, date



B. KEMPER

CEO

Identification of the signatory

## 9.2 UKCA Declaration of Conformity

Designation: Welding fume filter unit  
 Series: MaxiFil stationär  
 Type: **65850** (possibly different article numbers for other product variants)  
 Machine ID: See name plate in front section of this operating manual  
 This product is developed, designed and manufactured in accordance with the UKCA directives  
 Supply of Machinery (safety) Regulations 2008

The product continues to comply with the provisions of the  
 Electromagnetic Compatibility Regulations 2016  
 Electrical Equipment (Safety) Regulations 2016

Company: At the sole responsibility of  
**KEMPER GmbH**  
 Von-Siemens-Str. 20, D-48691 Vreden

The following designated standards and technical specifications have been applied:

- BS EN ISO 12100:2010 Safety of machinery - General principles for design
- BS EN ISO 13857:2019 Safety of machinery - Safety distances
- BS EN ISO 13854:2019 Safety of machinery
- BS EN ISO 21904-1:2020 Health and safety in welding and allied processes
- BS EN IEC 61000-6-2:2019 Electromagnetic compatibility (EMC) - Part 6-2: Generic standards - Immunity standard for industrial environments
- BS EN IEC 61000-6-4:2019 Electromagnetic compatibility (EMC) - Part 6-4: Generic standards - Emission standard for industrial environments
- BS EN 60204-1:2018 Safety of machinery - Electrical equipment of machines
- BS EN ISO 13849-1:2016 Safety of machinery - Safety-related parts of control systems
- BS EN IEC 63000:2018 Technical documentation for the assessment of electrical and electronic products with respect to the restriction of hazardous substances

A complete list of standards, directives and specifications applied is available from the manufacturer. The operating manual belonging to the product is available.

Additional information:

If it is not used for as intended or the design is altered, the Declaration of Conformity expires, unless confirmed in writing by us as manufacturers.

UK Authorised Representative (for authorities only): Mr. Marc Crawford  
 United Kingdom KEMPER (U.K.) Ltd.  
 Venture Court, 2 Debdale Road, Wellingborough, Northamptonshire NN8 5AA

Vreden, 29.04.2025  
 Place, date

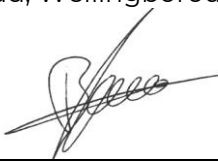
  
 B. Kemper

CEO  
 Identification of the signatory

### 9.3 Technical data

<b>Designation</b>	<b>Type</b>
<b>Filter</b>	65850
Filter stages	2
Filter method	Storage filter
Cleaning method	--
Filter surface m <sup>2</sup> [ft <sup>2</sup> ]	42 [452]
Number of filter elements	1
Total filter surface m <sup>2</sup> [ft <sup>2</sup> ]	42 [452]
Type of filter	Safe Change Filter (SCF)
Filter material	Non-woven polyester
Filter efficiency ≥ %	99.5
Welding fumes class	W3
IFA test standard	DIN EN ISO 21904-1+2
Filter class/Dust classification	E12
<b>Basic data</b>	
Maximum fan capacity m <sup>3</sup> /h [CFM]	3000 [1766]
Extraction capacity m <sup>3</sup> /h [CFM]	1000 [589]
Vacuum Pa [inch WC]	3200 [13]
Motor power kW [hp]	1.5 [2.01]
Power supply/rated current/protection type/ISO class	See name plate
Permissible ambient temperature °C [F]	-10 to +40 [+14 to +104]
Duty cycle %	100
Noise level dB(A)	72
Compressed air supply bar [PSI]	--
Compressed air consumption/compressed air class NI/min [CFM]	--
Dimensions of the basic product (W x H x D)	See dimension sheet
Basic product weight kg [lbs]	125 [276]
<b>Additional information</b>	
Fan type	Radial fan

Tab. 16: Technical data

**9.4 Dimensions sheet**

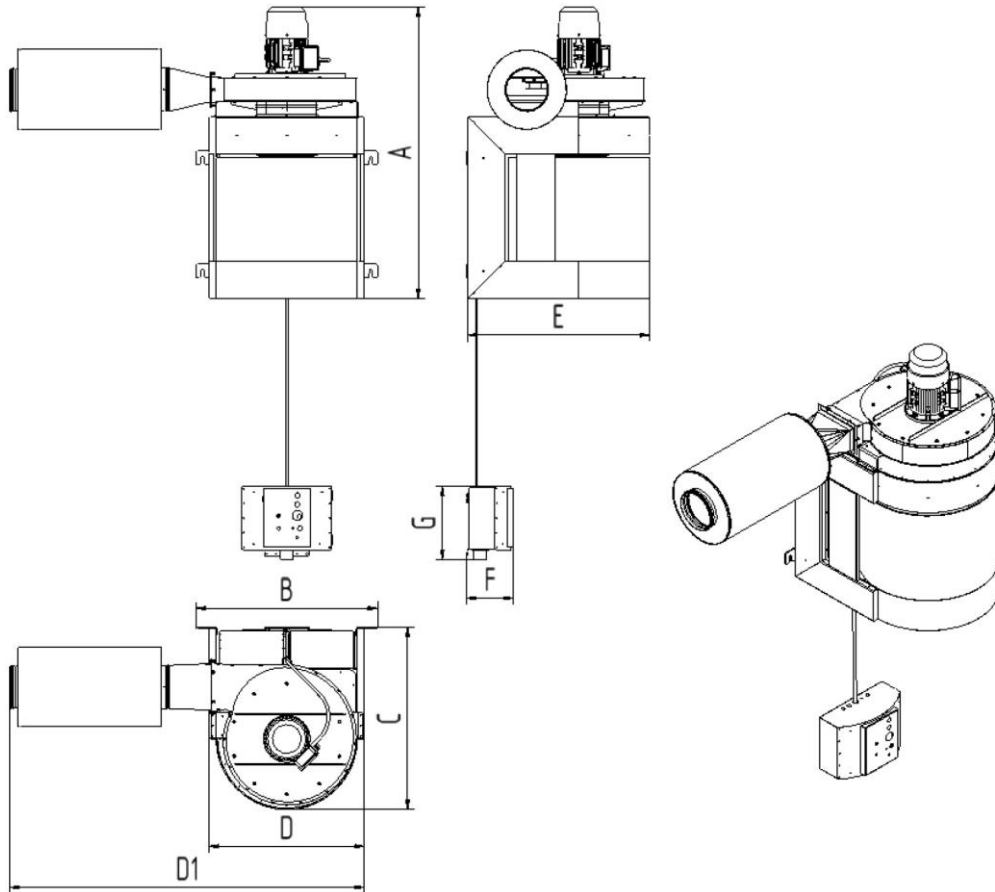

Fig. 17: Dimensions sheet

Symbol	Dimensions mm [in]	Symbol	Dimensions mm [in]
A	1237 [48.7]	D1	1506 [59.3]
B	771 [30.4]	E	771 [30.4]
C	775 [30.5]	F	119 [4.7]
D	660 [26.0]	G	308 [12.1]

Tab. 17: Dimensions table

## 9.5 Spare parts and accessories

Consec. no.	Description	Pos. no.
1	Extraction hood	7910300
2	Extraction hood with LED lamps and switches	79103040
3	Hose for extraction arm, 2 m, Ø 150 mm	1140348
4	Hose for extraction arm, 3 m, Ø 150 mm	1140349
5	Hose for extraction arm, 4 m, Ø 150 mm	1140350
6	Filter element 42 m <sup>2</sup>	1090517
7	Automatic start/stop	94102702

Tab. 18: Spare parts and accessories



**Deutschland (HQ)****KEMPER GmbH**

Von-Siemens-Str. 20  
D-48691 Vreden  
Tel. +49 2564 68-0  
Fax +49 2564 68-120  
mail@kemper.eu  
www.kemper.eu

**United Kingdom****KEMPER (U.K.) Ltd.**

Venture Court  
2 Debdale Road  
Wellingborough  
Northamptonshire NN8 5AA  
Tel. +44 1327 872 909  
Fax +44 1327 872 181  
mail@kemper.co.uk  
www.kemper.co.uk

**France****KEMPER sàrl**

7 Avenue de l'Europe  
F-67300 Schiltigheim  
Si vous appelez de France  
Tél. +33 800 91 18 32  
Fax +33 800 91 90 89  
De Belgique ou de l'étranger  
Tél. +492564 68-135  
Fax +492564 68-40135  
mail@kemper.fr  
www.kemper.fr

**China****KEMPER China**

Floor 2, Building 6  
No. 500 Huapu Road  
Shanghai 201799  
P.R. of China  
Tel. +86 (21) 5924-0978  
Fax +86 1852-1069-401  
info@kemper-china.com.cn  
www.kemper.cn.com

**Česká Republika****KEMPER spol. s r.o.**

Pyšelská 393  
CZ-257 21 Poříčí nad Sázavou  
Tel. +420 317 798-000  
Fax +420 317 798-888  
mail@kemper.cz  
www.kemper.cz

**United States****KEMPER America, Inc.**

2460 Industrial Park BLVD.  
Cumming, GA 30041  
Tel. +1 770 416 7070  
Fax +1 770 828 0643  
info@kemperamerica.com  
www.kemperamerica.com

**Nederland****KEMPER B.V.**

Demmersweg 92  
Begane grond  
7556 BN Hengelo  
Tel. +492564 68-137  
Fax +492564 68-120  
mail@kemper.eu  
www.kemper.eu

**España****KEMPER IBÉRICA, S.L.**

Avda Diagonal, 421 3º  
E-08008 Barcelona  
Tel. +34 902 109-454  
Fax +34 902 109-456  
mail@kemper.es  
www.kemper.es

**India****KEMPER India**

55, Ground Floor, MP Mall  
MP Block, Pitam Pura  
New Delhi -110034  
Tel. +91.11.42651472  
mail@kemper-india.com  
www.kemper-india.com

**Polska****Kemper Sp. z o.o.**

ul. Grzybowska 87  
00-844 Warszawa  
Tel. +48 22 5310 681  
Faks +48 22 5310 682  
info@kemper.pl  
www.kemper.pl

